

Technical Information
Ampere-hour Meters
AZ 4000 DSZ



Contents

1.	Important	3
2.	Introduction	4
2.1	Description of the controls	4
3.	Operating principle	5
3.1	Block circuit diagram	5
4.	Instrument descriptions	6
5.	Evaluation of summation currents with the potential Isolation modules TMD U/U and the AZ 4000 DSZ	8
5.1	Functional circuit diagram	8
6.	Description electrical dosing systems	9
6.1	Introduction	9
6.2	Electronic dosing system DSZ	10
6.3.	Functional circuit diagram DSZ on dosing equipment	10
7.	Ampere-hour meter AZ 4000 DSZ with magnetic-dosing pump	11
7.1	Functional circuit diagram AZ 4000 DSZ with gamma/4-b	11
8.	Technical data	12
9.	Connection diagrams	13
9.1	Connection AZ 4000 DSZ	13
9.2	Connection isolating modules to AZ 4000 DSZ	14
9.3	Connection DSZ to magnetic-dosing pump gamma/4-b	15
10.	Setting instructions for the counters Series AZ...	16
10.1	Preparation of the unit	16
10.2	Setting procedure	16
10.3	Setting tables Ampere- hour meter / Ampere- minute meter	17
10.3.1	Ampere- hour meter AZ 4000 DSZ	17
10.3.2	Ampere- minute meter AZ 4000 DSZ	18

1. Important

Before starting up the equipment the Operating Instructions should be read carefully.

Special attention must be paid to all notes referring to dangerous hazards in the use of the equipment.

This equipment is constructed and tested to Protection Class II according to **DiN 57 411 Part 1, VDE 0411 Part 1**. Protective measures for electronic measuring equipment. It has left the factory in perfect condition with regard to all safety aspects.

Any repair or any replacement of components must only be carried out by a specialist fully familiar with the hazards involved and with the contents **VDE Regulations 0411**.

2. Introduction.

In the Ampere-hour Meters Az 2000 - 4000 we have developed a modern equipment design for electroplating technology.

The units are of modular construction. They are therefore very easy to service and all models can be supplied from stock on short delivery.

These measuring instruments can be used as

- **amper-hour meter**
- **amper-minute meter**
- **amper-second meter**
- **metal weight meter**

The calibration can be changed by the user himself.

All models are available with built-in electronic dosing system which offers current-related dosing of chemical additives.

The automatic uniform dosing of additives ensures a constant bath composition (and therefore uniform quality).

2.1 Description of the controls

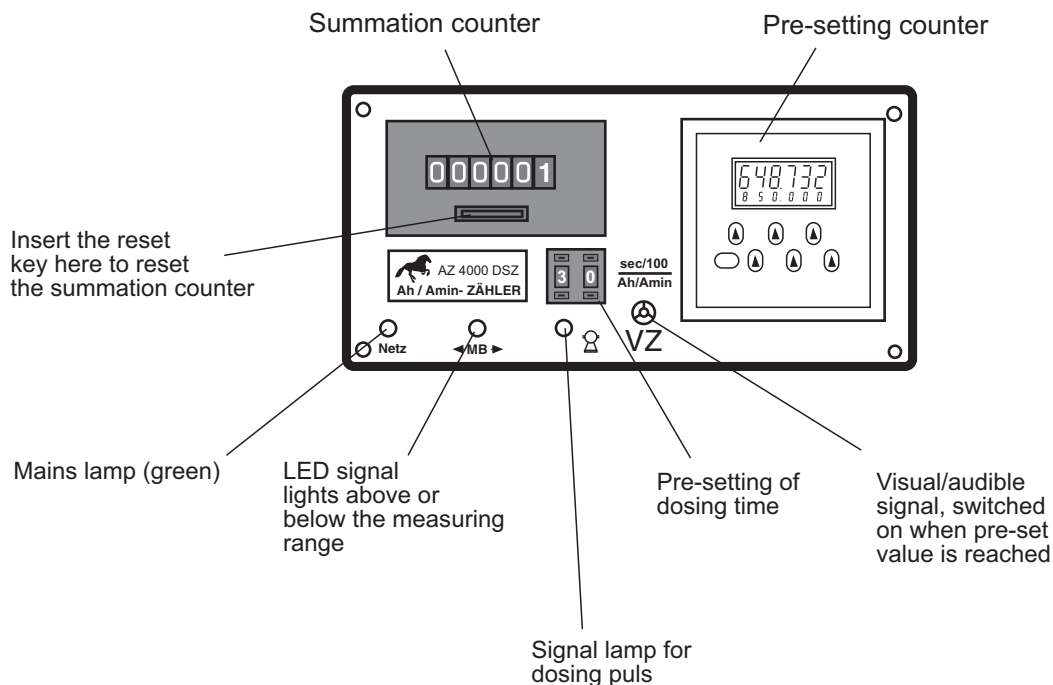

3. Operating principle

All the instrument models have the same basic design.

A voltage proportional to the plating current is produced across the measuring resistance (shunt); this is amplified in the input amplifier. A voltage/frequency converter changes the amplified voltage into a proportional frequency.

A programmable frequency divider ensures that the Ah or Amin reading corresponds to the summation current.

The LED „MB Monitor" is operated when the measured voltage exceeds a pre-set maximum or falls below a pre-set minimum. It indicates that reliable measurement is no longer ensured.

When the voltage falls below the minimum value, a pulse blockage is activated which stops the count.

The counting pulses of the summation counter are also used to control the electronic dosing system.

3.1 Block circuit diagram

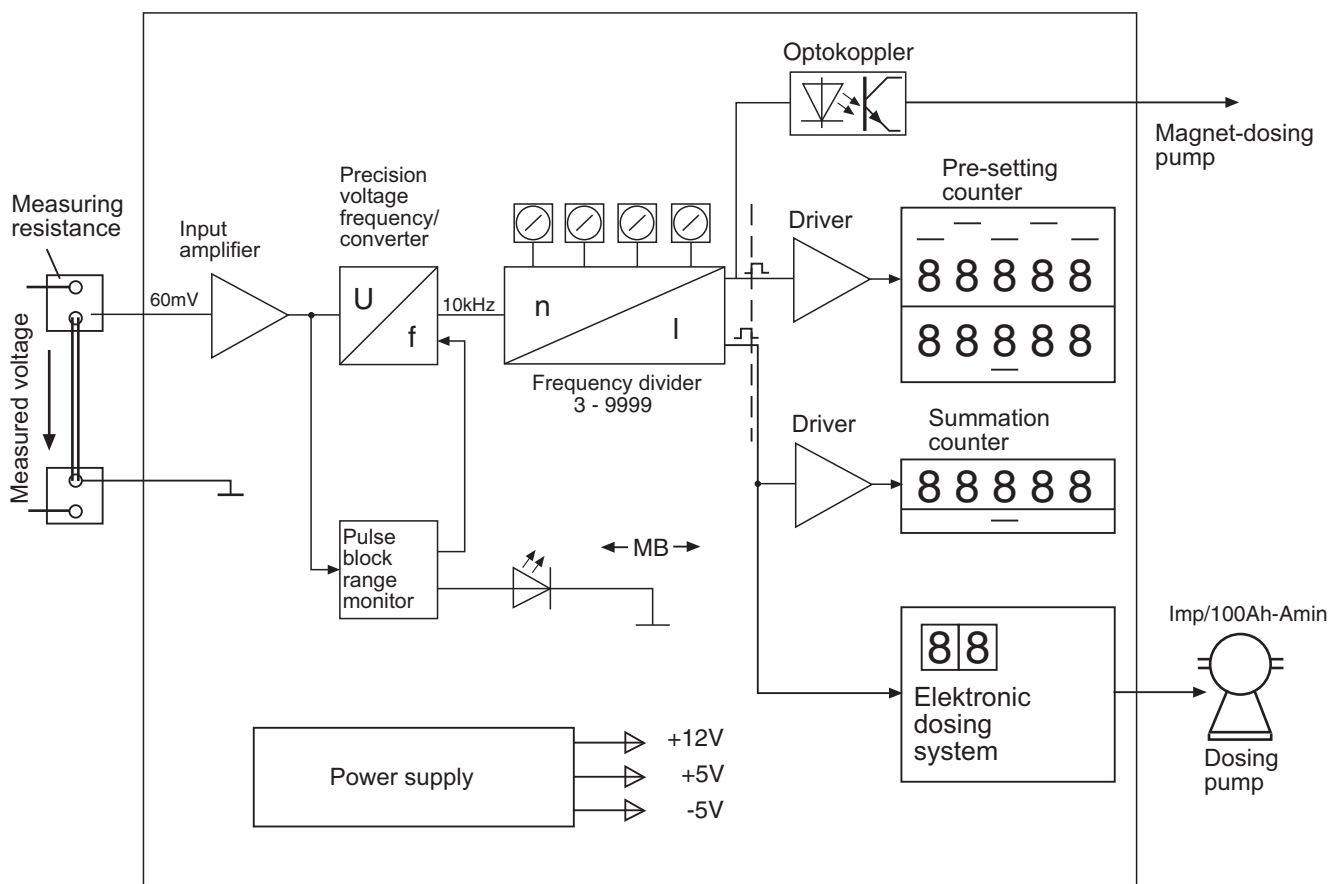

4. Instrument descriptions

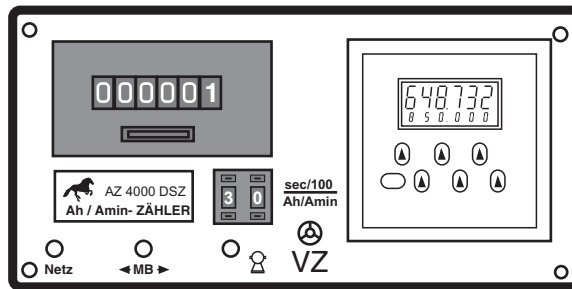

AZ 4000 DSZ

This counter has an electronic 6-digit pre-setting counter which is programmable. Resetting is possible manually from the front and externally by a push-button.

Connection to the gamma/4-b magnet-dosing pump is possible with the dosing system.

Range monitor -MB-

All Ah counters **AZ 4000 DSZ** are equipped with a signal monitoring device. If the input voltage is smaller than approx. 1 mV and larger than approx. 150 mV (nominal signal voltage = 60 mV) this is indicated by the LED marked MB. Under these conditions reliable measurement is no longer assured.

The following operating Mode of the presetting counter are programmable:

1. Counter: adding (Add) or subtracting (Sub) Mode.
2. Automatic resetting(loop on) with a impulse at the relay-output or a constant signal at the relay output (loop off) by reaching the presetting (Add) or Zerro (Sub).
3. Output: Relay with potential-free contact programmable as normally open (no) or normally closed (nc) contact.
The relay is active by reaching the presetting (Add) or Zerro (Sub).
4. The length of the impulse (loop on) can be closed (100, 200, 300, 400, 500 msec).
5. Decimal place.

Standard Settings:

- | | | |
|----|------------------------|---------------|
| 1. | Count: add | (Count - Add) |
| 2. | Relay: Constant signal | (LooP - off) |
| 3. | Relay: Normally open | (rELAY - no) |
| 4. | Lenght of impulse | (dELAY - 100) |
| 5. | No Decimal place | (dP - 0) |

Setting the Operating Mode and Operational Parameters:

In order to reach the programming Mode you must depress the reset key and the keys of the decade 5 and 6 simultaneously. On the lower line of the display the message INIT appears together from 5 to 0 in steps of seconds. If, within this period the depressed keys are released, the previous operating mode will become active again. If the keys are released after reaching zero, the first parameter is activated and displayed.

The key of the first decade allows to select the requested function within the parameters (e.g. add/subtract) and the 6th decade-key selects the next parameter. After the last parameter "dp" the program jumps to the beginning. To leave this program routine the user must step through all parameters (from the beginning to the end) with NO CHANGES at all.

Note: Whenever this routine is selected the program will jump to the beginning, the previous parameters will get lost and the count as well as the preset values are zeroed.

Operating the counter:

Setting or resetting: Press the red SET button or apply a pulse to the reset input to set the counter to zero in the accumulating mode, to the presetting in subtracting mode.

Presetting: The presetting is indicated on the lower row of digits. To set it, use the 6 presetting buttons assigned to each decade. The set value will be accepted with the next set or reset operation.

Overflow and underflow: In the accumulating mode the overflow is 999 999 to 0; in the subtracting mode it is 0 to 999 999. The output signal remains unaffected.

Lo-Bat indicator: When the battery charge is too low, "Lo-bAt" appears in the lower display. This flashes in a two-second rhythm. When "Lo-bAt" is indicated, the batteries should be exchanged as soon as possible.

Changing the batteries: Push the battery cover back and remove the batteries, making certain that polarity is correct (observe "-" terminal on PCB).

Note: Changing the batteries should not take longer than 2 min., otherwise the count and preset values as well as the parameters will get lost and therefore must be set again.

5. Evaluation of summation currents with the potential Isolation modules TMD U/U and the AZ 4000 with equal shunt resistance data

When several plating rectifiers in a plant are operated with a common electrolyte, manual or automatic dosing of electrolyte additives involves the total summation current. This is achieved by connecting to each plating rectifier a TMD U/U and evaluating the plating current through the so-called shunt voltage.

The outputs of the potential isolation modules TMD U/U are connected in series (summed) and passed to the **AZ 4000 DSZ** as the total summation current. The AZ 4000 is used for indicating the total summation current, and for controlling the dosing equipment through the built-in electronic dosing system.

The voltage measured by the **AZ 4000 DSZ** therefore corresponds directly to the plating current. (see drawing).

5.1 Functional circuit diagram

The output of the TMD is corresponding to the shunt current, eg. 500A = 500mV. So the relation is 1:1. (1A = 1mV)

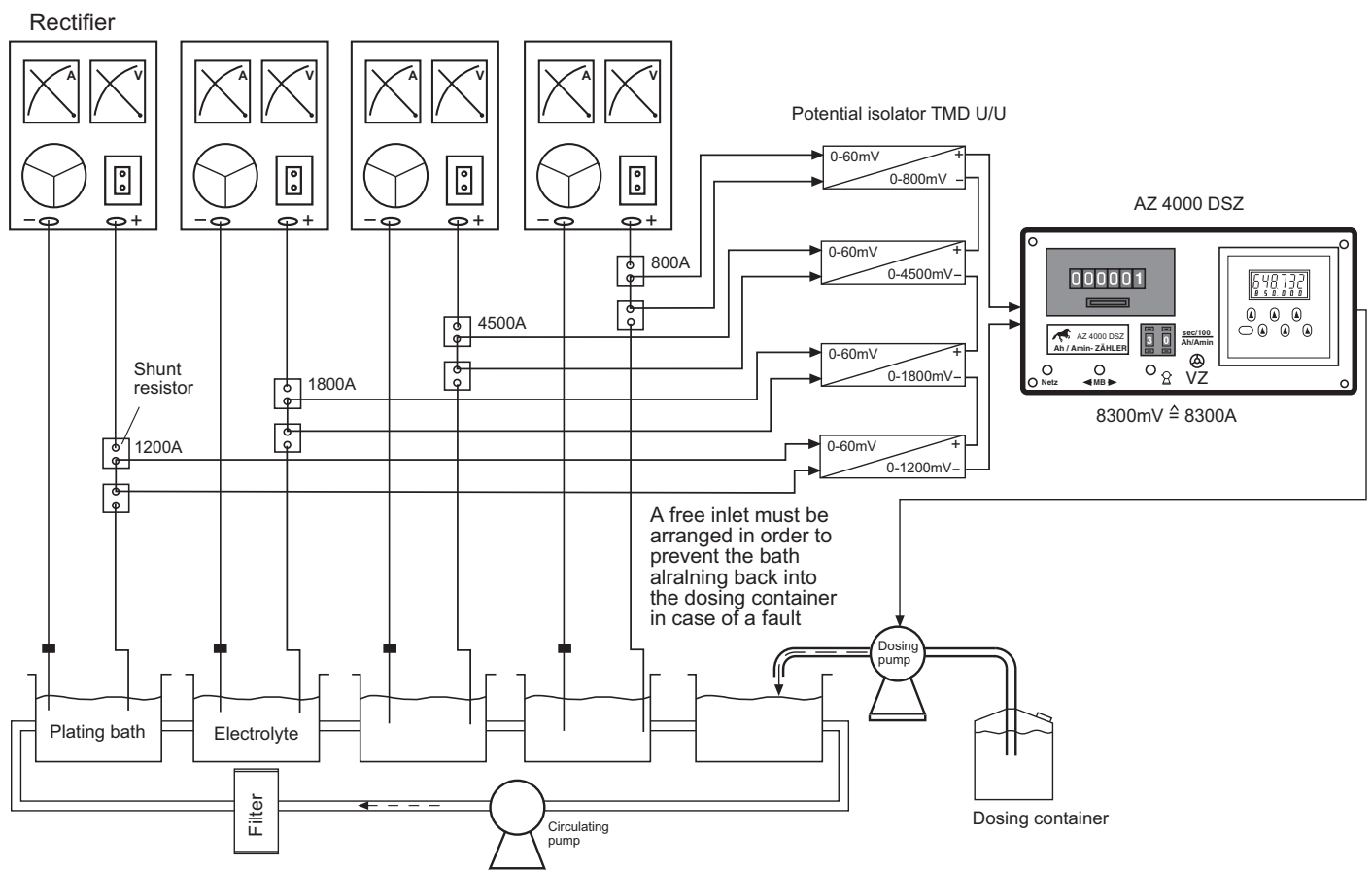

6. Description electrical dosing systems

6.1 Introduction

During electrochemical processes in electroplating baths the electrical current causes metals to be deposited.

The quantity of metal deposited depends on the magnitude of the electrical current, the plating time, and the electrochemical equivalent of the metal.

In order to ensure that the plating bath has a uniform quality it is necessary to replace the deposited metal and to feed in other chemical additives.

It provides for accurate, current-related dosing of the necessary substances.

We have developed the following dosing system for the different applications:

- **DSZ:** selection of the dosing time in sec/min per 10/100/1000 Ah/Amin
- **AZ/gamma/4-b** Setting the Ah/Amin after which a control pulse output is produced. This is selected directly on the programmable gamma/4-b membrane dosing pump.

The operation of the electronic dosing systems is described in detail in Sections 6.2 - 6.5.1.

The basic arrangement of a dosing system is illustrated in the functional circuit diagram below.

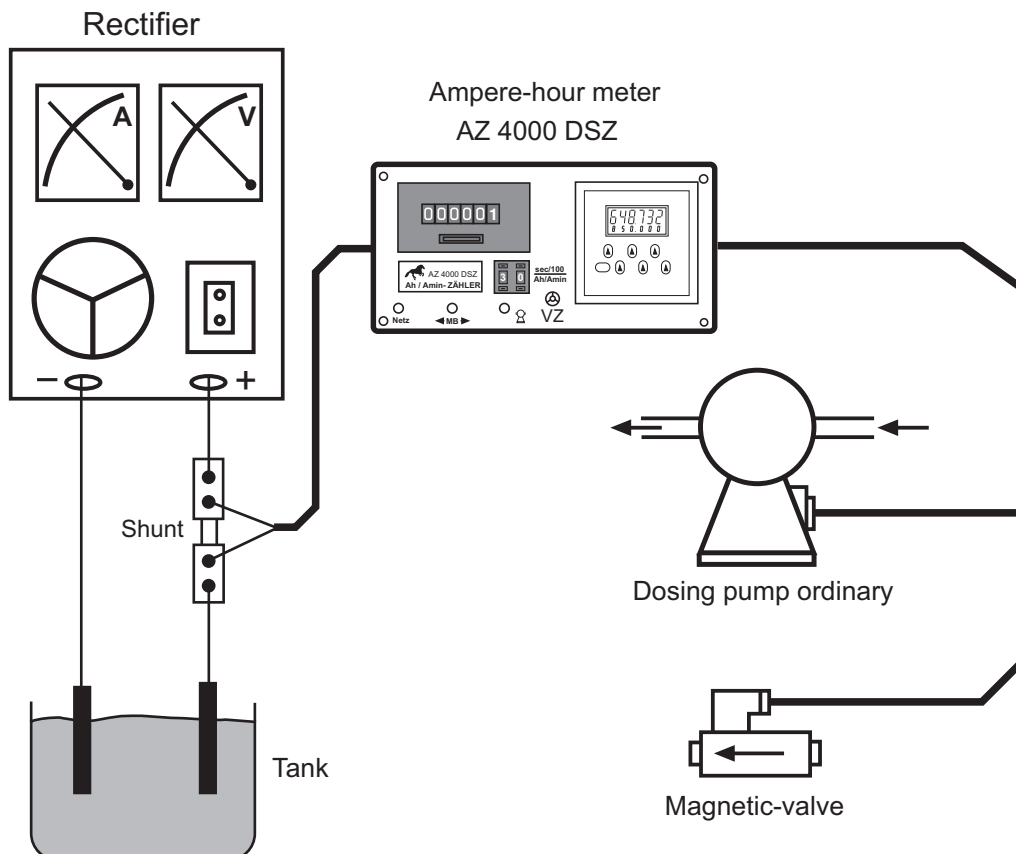

6.2 Electronic dosing system DSZ

The dosing System DSZ causes a timer to be started up at intervals of **10/100** or **1000 Ah/Amin**.

The on-time of the timer can be adjusted between 1 and 99 seconds on the front panel of the AZ. An option is an build in adjustment range.

Example:

Selected on-time: 30 sec/100 Ah/Amin.

Operating mode: every 100 Ah/Amin a dosing pump or a solenoid valve is energised or opened for a duration of 30 seconds.

The dosing quantity depends on the output of the pump or on the flow rate at the solenoid valve.

The output of the dosing system DSZ consists of a volt-free switching contact (8 A / 250 V) which controls the supply voltage of the dosing pump or solenoid valve.

6.3 Functional circuit diagram DSZ on dosing equipment

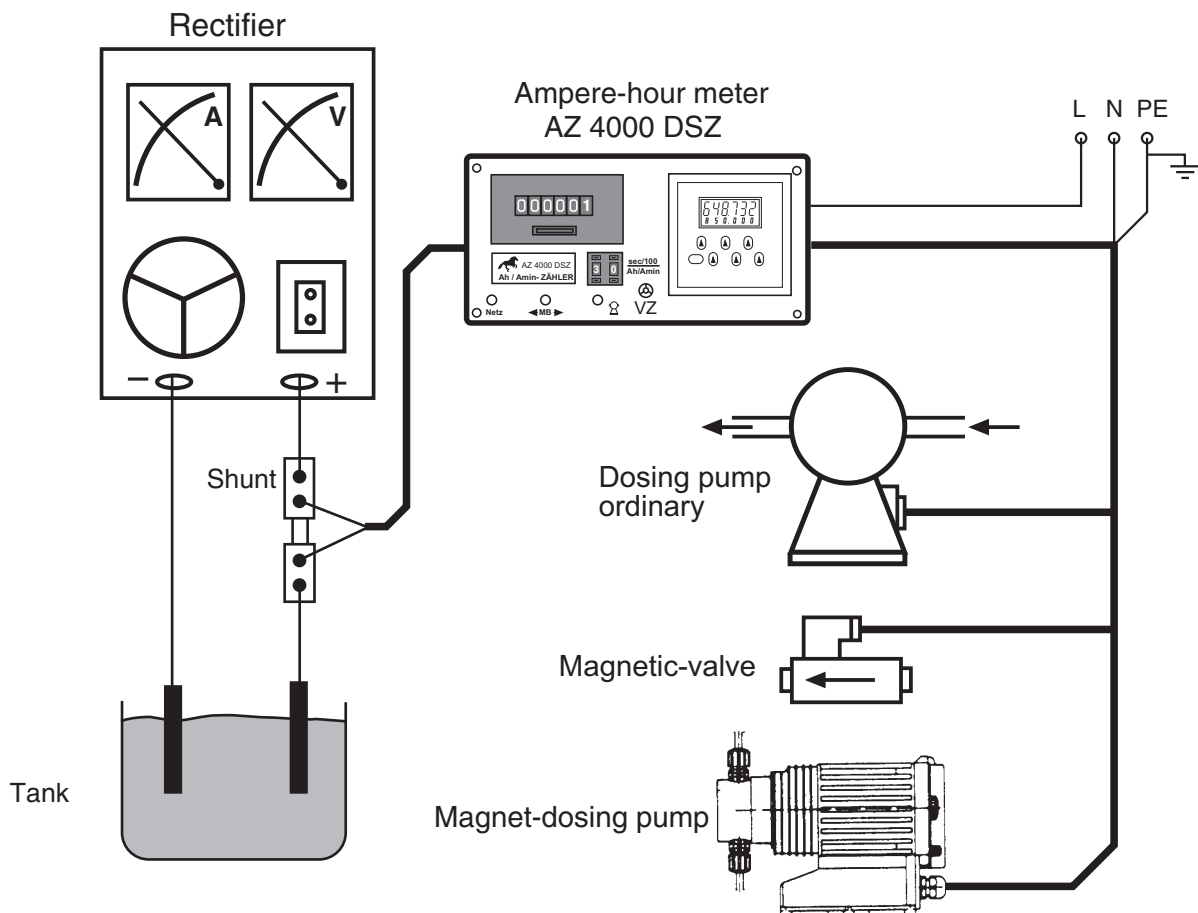

7. Ampere-hour meter AZ 4000 with magnetic dosing pump

Operating an ampere-hour meter in conjunction with the programmable magnetic membran dosing pump gamma/4-b produces dosing in accordance with a pre-selected number of Ah/Amin.

On each step of the totalising counter or presetting counter the ampere-hour counter outputs a pulse through its optocoupler output to the dosing pump gamma/4-b.

The gamma /4-b pump must now be set to produce a certain number of dosing strokes for each step of the totalising or presetting counter.

In the conversion of Az pulses to dosing strokes there is a choice between a step-up and a step-down ratio of the control pulses.

Step-up: a single totalising or presetting counter pulse of the AZ generates n dosing strokes.

Step-down: n totalising or presetting counter pulse of the AZ generate a single dosing stroke.

7.1 Functional circuit diagramm AZ with gamma/4-b

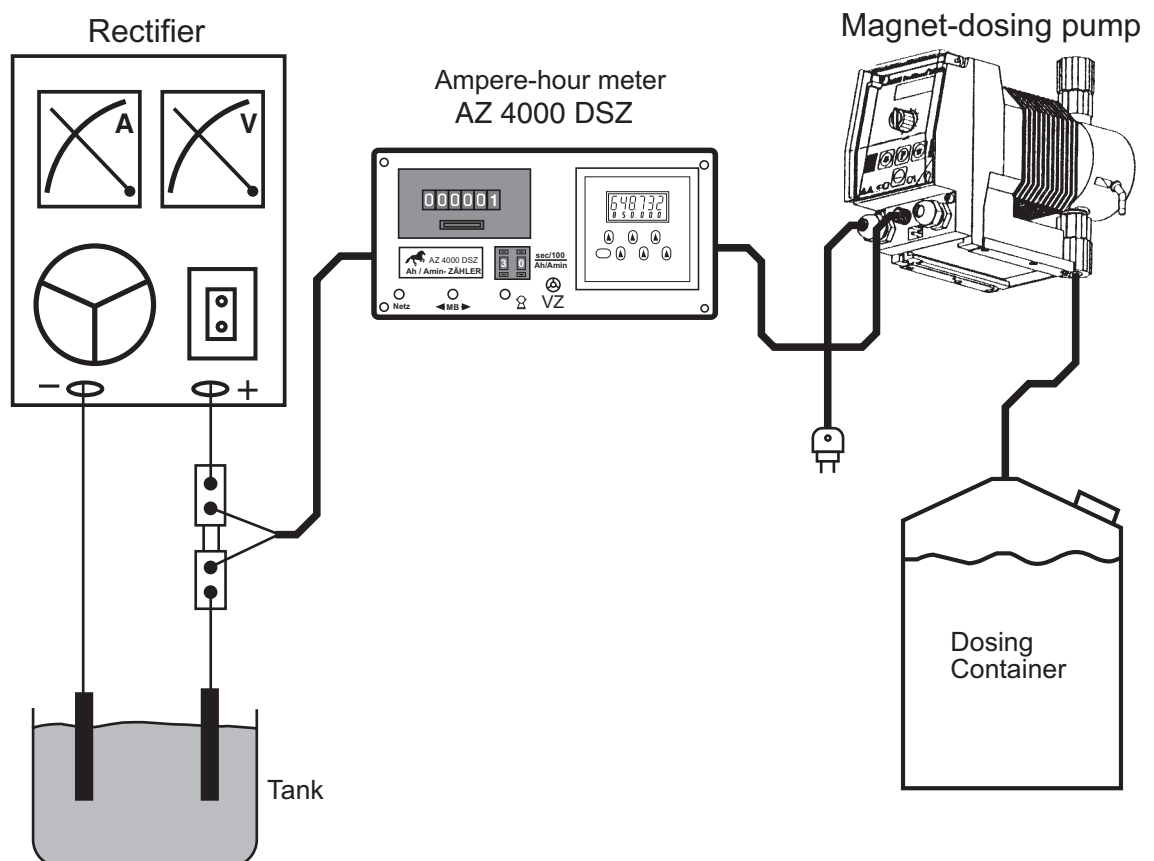

8. Technical data

Countermodel	AZ 2000	AZ 2000 DSZ	AZ 4000	AZ4000 DSZ
Summation counter 6-digit, mechanical	X	X	X	X
Pre-sefling counter 6-digit, electronic			X	X
Floating Opto- coupler output to control the gammal4-b pump	X		X	
Floating relay output to control the gamma/4-b pump		X		X
Relay output 8 AI250 V 50160 Hz			X	X
Measurement accuracy	0,1%	0,1%	0,1%	0,1%
Ambient temperature	0-50°C			
Supply	230V 50 Hz/60 Hz (Other voltages to special order)			
Protection	IP 44			
Weight	550 g	1000 g	1100 g	1150 g
Panel cut-out (mm)	90,5x43	137x66	137x66	137x66
Dimensions (mm) WxHxD	48x96x180	72x144x180	72x144x180	72x144x180

Note: If a contactor operated by the relay output does not drop out when the relay contact is open, the RC interference suppressor next to the relay output has to be removed. In order to avoid severe wear on the relay contacts the RC interference suppressor is then connected in parallel with the inductive load.

9. Connection diagrams

9.1 Connection AZ 4000 DSZ

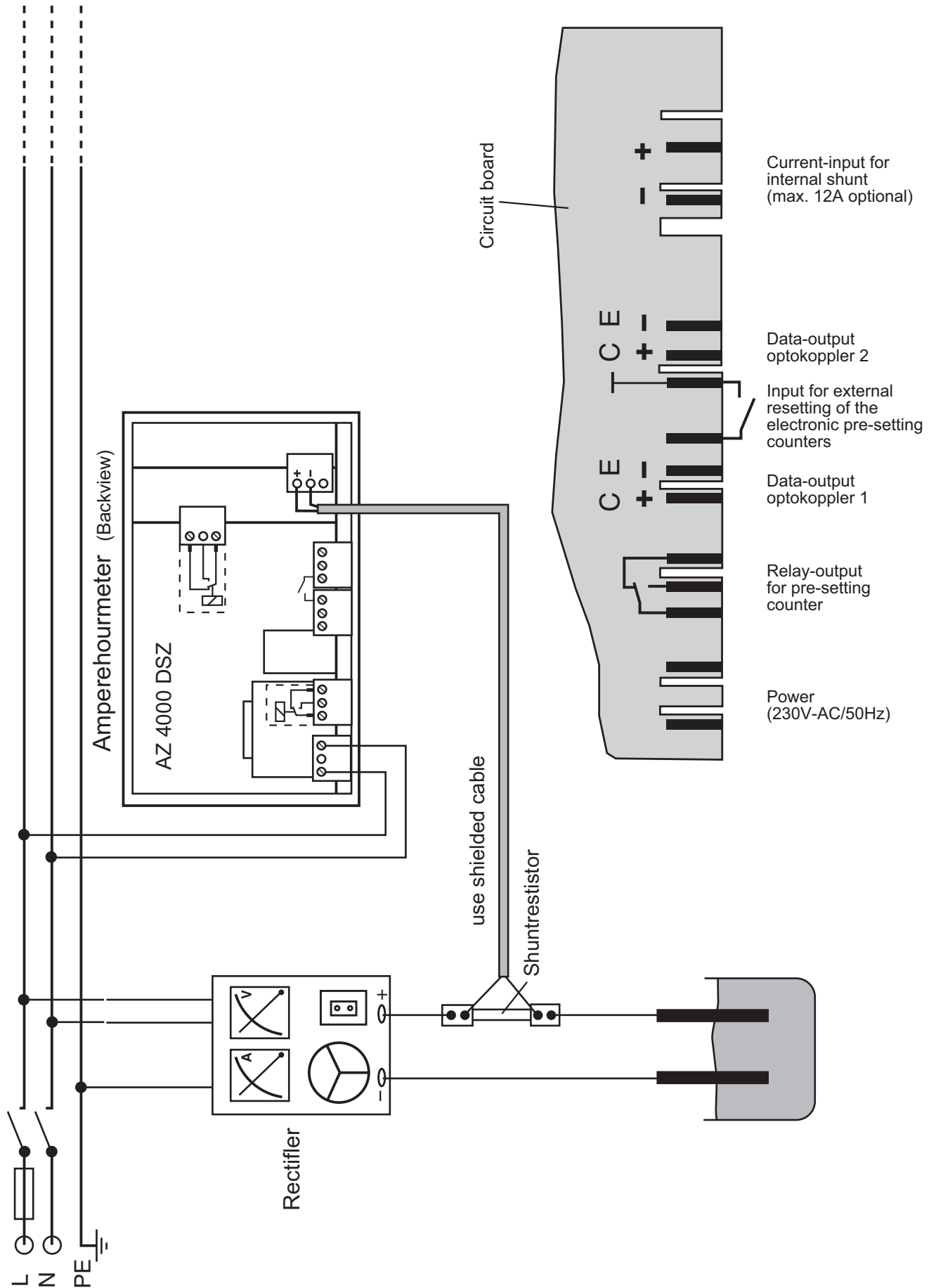

9.2 Connection isolating modules to AZ 4000 DSZ

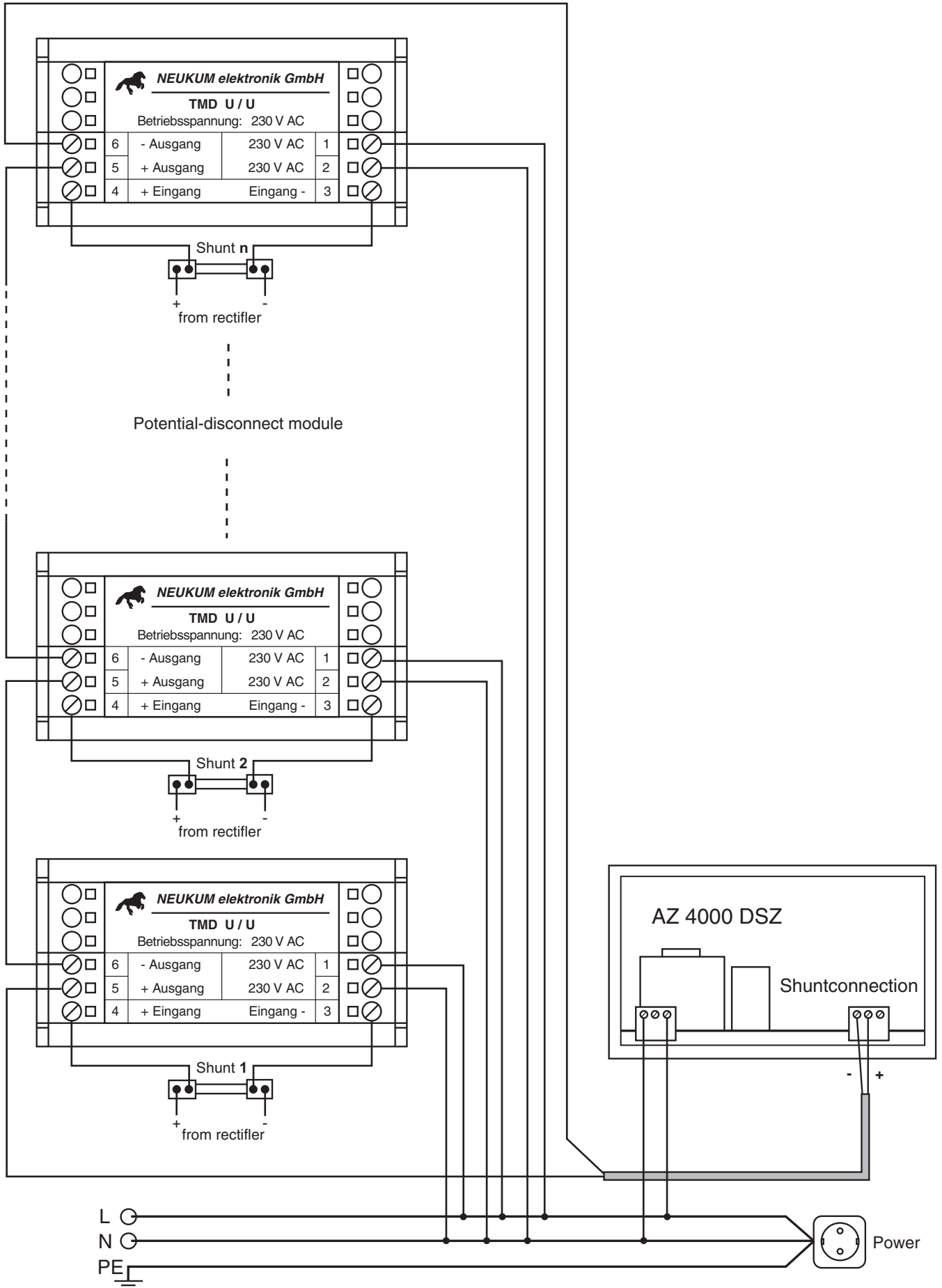

9.3 Connection DSZ to magnetic dosing pump gamma/4-b

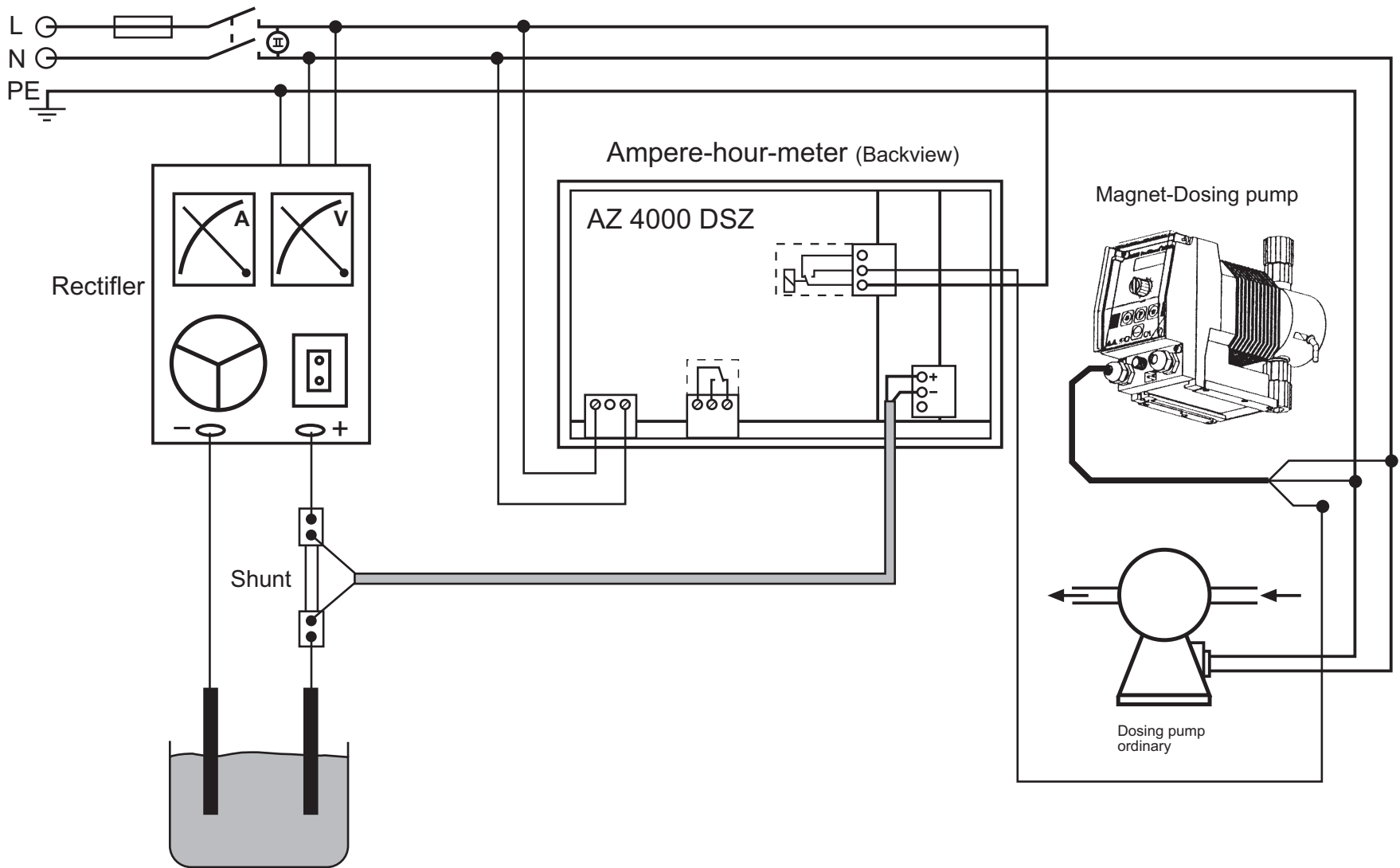

10. Setting instructions for the counters Series AZ....

The following notes and setting tables apply to the calibration of the AZ and to changing the indication accuracy (resolution).

10.1 Preparation of the unit

IMPORTANT:

Before opening the unit, check that it is not live!

Otherwise the operation is extremely hazardous!!

The circuit board must only be touched at the edges!

Make sure that you do not carry any electrostatic charges, otherwise the sensitive MOS components may be destroyed. Discharge any static charge by touching a metal object at ground potential, such as water pipe, earth connection, or a large metal object such as a bench.

AZ 4000 DSZ

1. Open the back panel and carefully remove the circuit board.
2. Make the adjustments according to the table. The location of the controls is shown in the diagrams below.
3. After the adjustments have been made, slide the circuit board back into the housing. Take care with the front and the controls. Replace the back panel.

10.2 Setting procedure

The rotary switches **SA, SB, SC, SD** are used to set the division ratio. The settings depend on the shunt resistance used, and also on the required measuring unit (Ampere-hour, Ampere-minute).

The equipment is set at the factory according to your order details. It can however readily be changed with reference to the tables. (Please use a small watchmaker's screwdriver!)

The pre-setting counter and summation counter each have in addition a set of **3** switches in order to determine the number of places after the decimal point. The tables show the values for the various shunt resistances.

Please note that the counters may have to be provided with a "**decimal point**" (label). Appropriate symbols are placed on the internal face of the housing back.

10.3 Setting tables Ampere-hour meter/Ampere-minute meter

10.3.1 Ampere-hour meter AZ 4000 DSZ

Shunt	Pre-setting switches				Summation counter reading / hour			Pre-setting counter reading / hour		
	A	B	C	D	S1	S2	S3	S4	S5	S6
40 A	9	0	0	0	0040,00	00040,0	000040	040,00	0040,0	00040
50 A	7	2	0	0	0050,00	00050,0	000050	050,00	0050,0	00050
60 A	6	0	0	0	0060,00	00060,0	000060	060,00	0060,0	00060
80 A	4	5	0	0	0080,00	00080,0	000080	080,00	0080,0	00080
100 A	3	6	0	0	0100,00	00100,0	000100	100,00	0100,0	00100
150 A	2	4	0	0	0150,00	00150,0	000150	150,00	0150,0	00150
200 A	1	8	0	0	0200,00	00200,0	000200	200,00	0200,0	00200
250 A	1	4	4	0	0250,00	00250,0	000250	250,00	0250,0	00250
300 A	1	2	0	0	0300,00	00300,0	000300	300,00	0300,0	00300
400 A	0	9	0	0	-	00400,0	000400	400,00	0400,0	00400
500 A	0	7	2	0	-	00500,0	000500	500,00	0500,0	00500
600 A	0	6	0	0	-	00600,0	000600	600,00	0600,0	00600
800 A	0	4	5	0	-	00800,0	000800	800,00	0800,0	00800
1000 A	0	3	6	0	-	01000,0	001000	-	1000,0	01000
1200 A	0	3	0	0	-	01200,0	001200	-	1200,0	01200
1500 A	0	2	4	0	-	01500,0	001500	-	1500,0	01500
2000 A	0	1	8	0	-	02000,0	002000	-	2000,0	02000
2500 A	0	1	4	4	-	02500,0	002500	-	2500,0	02500
3000 A	0	1	2	0	-	03000,0	003000	-	3000,0	03000
4000 A	0	0	9	0	-	-	004000	-	4000,0	04000
5000 A	0	0	7	2	-	-	005000	-	5000,0	05000
6000 A	0	0	6	0	-	-	006000	-	6000,0	06000
8000 A	0	0	4	5	-	-	008000	-	8000,0	08000
10000 A	0	0	3	6	-	-	010000	-	-	10000

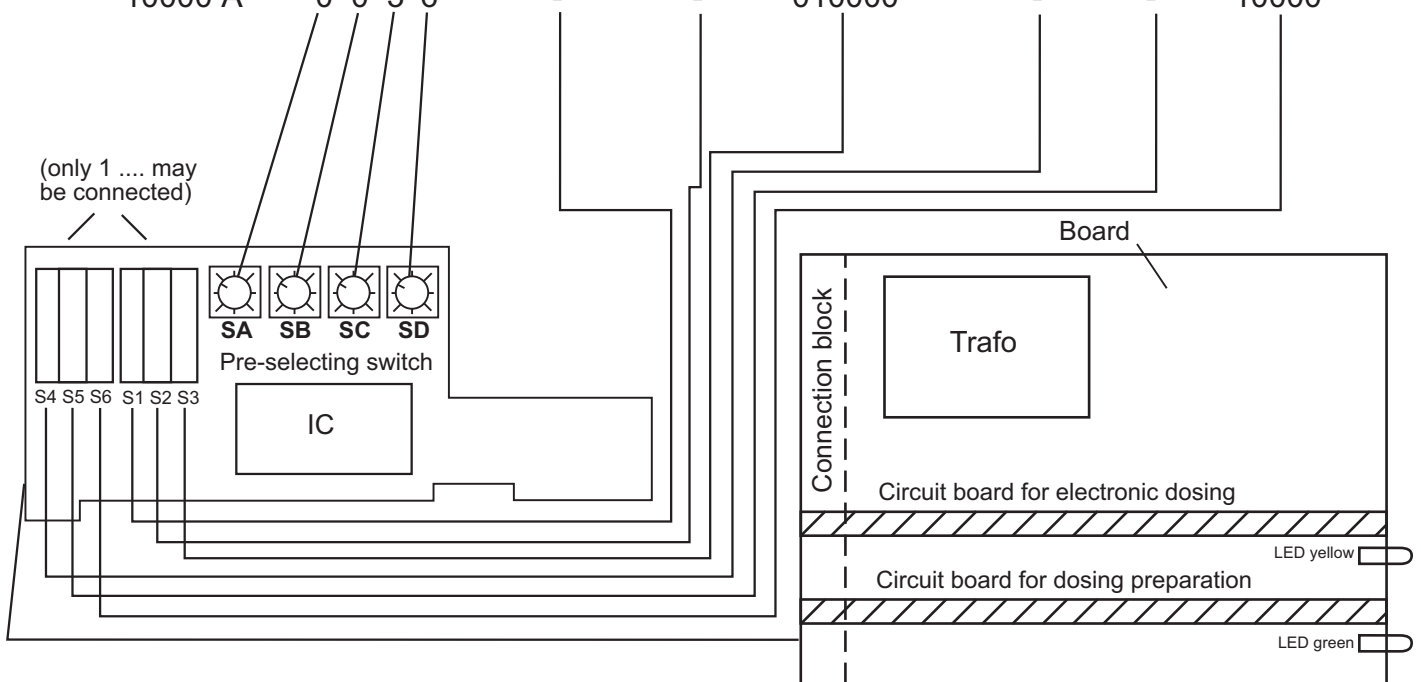

10.3.2 Ampere-minute meter AZ 4000 DSZ

Shunt	Pre-setting switches				Summation counter reading / minute			Pre-setting counter reading / minute		
	A	B	C	D	S1	S2	S3	S4	S5	S6
1 A	6	0	0	0	0001,00	00001,0	000001	001,00	0001,0	00001
2 A	3	0	0	0	0002,00	00002,0	000002	002,00	0002,0	00002
4 A	1	5	0	0	0004,00	00004,0	000004	004,00	0004,0	00004
5 A	1	2	0	0	0005,00	00005,0	000005	005,00	0005,0	00005
6 A	1	0	0	0	0006,00	00006,0	000006	006,00	0006,0	00006
10 A	0	6	0	0	-	00010,0	000010	010,00	0010,0	00010
15 A	0	4	0	0	-	00015,0	000015	015,00	0015,0	00015
20 A	0	3	0	0	-	00020,0	000020	020,00	0020,0	00020
25 A	0	2	4	0	-	00025,0	000025	025,00	0025,0	00025
40 A	0	1	5	0	-	00040,0	000040	040,00	0040,0	00040
50 A	0	1	2	0	-	00050,0	000050	050,00	0050,0	00050
60 A	0	1	0	0	-	00060,0	000060	060,00	0060,0	00060
100 A	0	0	6	0	-	-	000100	100,00	0100,0	00100
150 A	0	0	4	0	-	-	000150	150,00	0150,0	00150
200 A	0	0	3	0	-	-	000200	200,00	0200,0	00200
250 A	0	0	2	4	-	-	000250	250,00	0250,0	00250
300 A	0	0	2	0	-	-	000300	300,00	0300,0	00300
400 A	0	0	1	0	-	-	000400	400,00	0400,0	00400

